

SW ISOMETRIC VIEW
SCALE 1:20

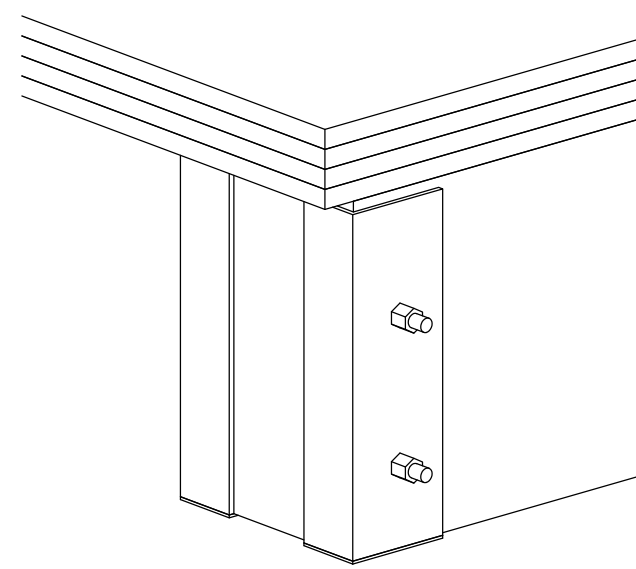

ISOMETRIC W/O GIRDER SUPPORT BOLT
SCALE 1:10

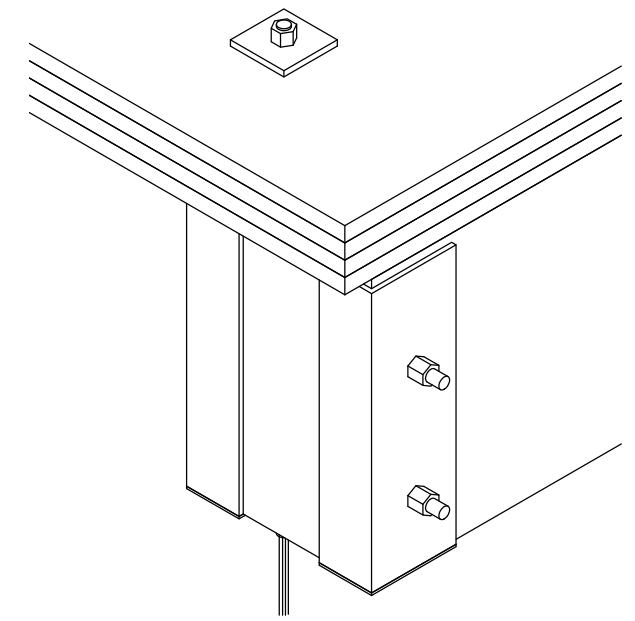

ISOMETRIC W/ GIRDER SUPPORT BOLT
SCALE 1:10

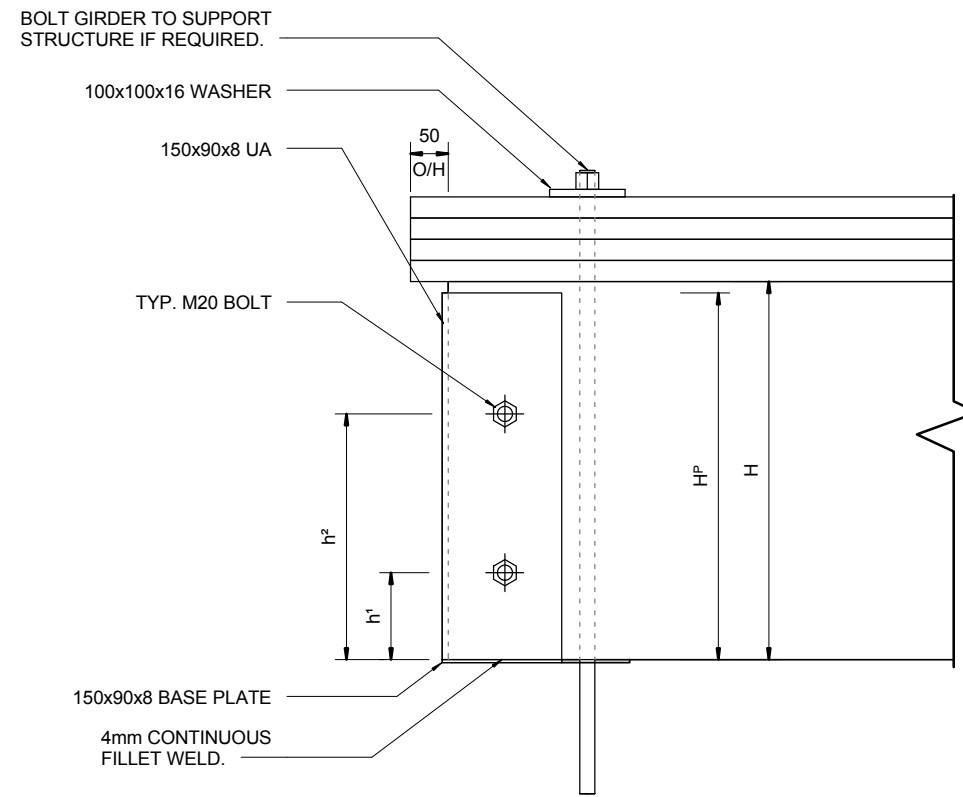
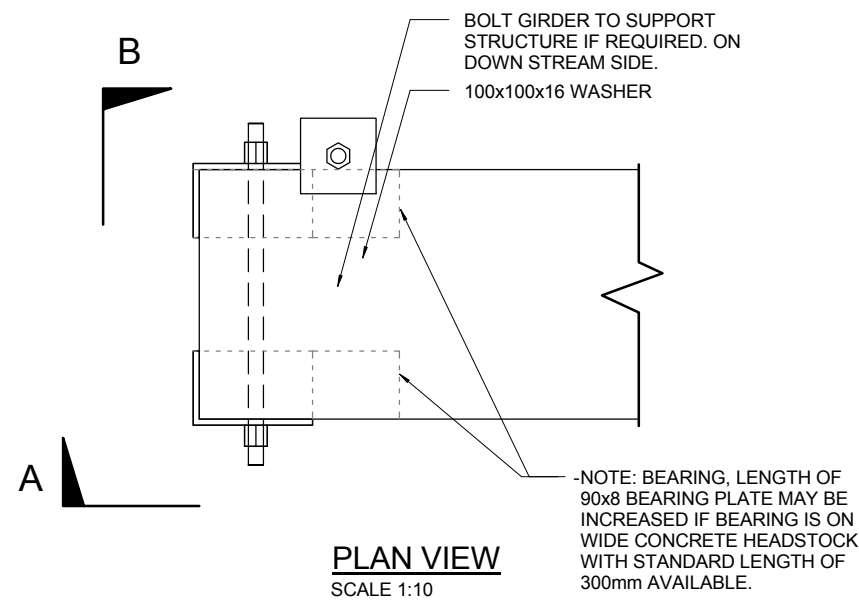

SECTION A
SCALE 1:10

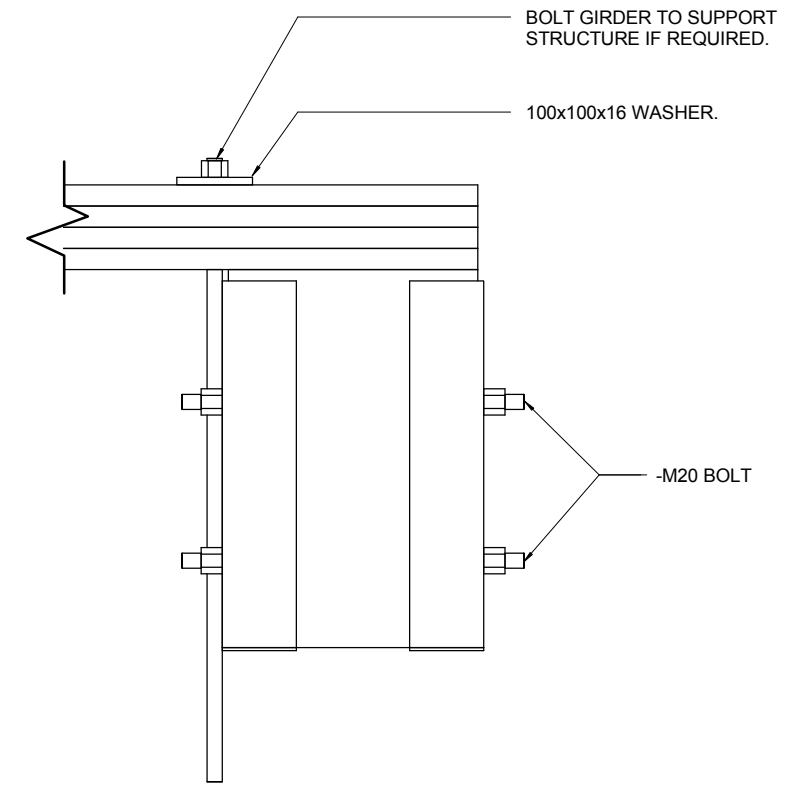

SECTION B
SCALE 1:10

LENGTH "L" (m)	GIRDER DEPTH "H" (mm)	BEARING PLATE HEIGHT "HP" (mm)	BOLT POSITION "h1" (mm)	BOLT POSITION "h2" (mm)
8	342	332	170	
10	445	435	150	300
12	555	545	150	405
15	780	770	200	580

COPYRIGHT

NOT TO BE REPRODUCED WITHOUT PERMISSION OF PNG FOREST PRODUCTS LTD

The Builder/Contractor shall verify job dimensions prior to any work commencing. Figured dimensions shall take precedence over scaled work.

NORTH POINT

REVISION	DESCRIPTION
1	ISSUED FOR APPROVAL
2	ISSUED FOR APPROVAL
3	REVISED WHERE MADE
4	REVISED WHERE MADE

DATE

24/09/15
09/10/15
07/03/16
18/04/16

PROJECT

GIRDER BEARING PLATES/ CAPS NIUBRIDGE HPF MODULAR SYSTEM

DRAWING NAME

PLAN/ SECTIONS/ ISOMETRIC VIEWS

DATE

SEP2015

DRAWN

HB

PROJECT N.O

150161

SCALE

1:10

CHECKED

PR

SHEET NUMBER

A104

SHEET SIZE

@ A3

APPROVED

TH

REVISION

4

PNGFP FOREST PRODUCTS

PO BOX 88, BULOLO, MP, PNG
PHONE: 474-5211
FAX: 474-5160
Email: Bridgesales@pngfp.com

